

THIS DOCUMENT AND THE INFORMATION CONTAINED IN IT ARE PROPRIETARY AND CONFIDENTIAL TO M.T.I. NO PERSON IS ALLOWED TO COPY, REPRINT, REPRODUCE OR PUBLISH ANY PART OF THIS DOCUMENT, NOR DISCLOSE ITS CONTENTS TO OTHERS, NOR MAKE ANY USE OF IT, NOR ALLOW OR ASSIST OTHERS TO MAKE ANY USE OF IT - UNLESS BY THE PRIOR WRITTEN EXPRESS AUTHORIZATION OF M.T.I. AND THEN ONLY TO EXTENT AUTHORIZED. (C) COPYRIGHT - M.T.I. WIRELESS EDGE LTD.

SHEET REVISION STATUS

5	4	3	2	1	SHEET NO
					LATEST REV

REVISIONS

REV.	ECO	DESCRIPTION	DATE	APPROVED
		PRELIMINARY		

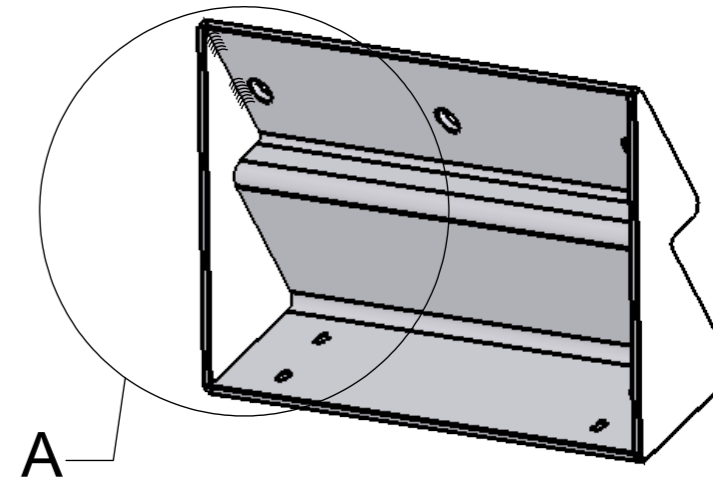
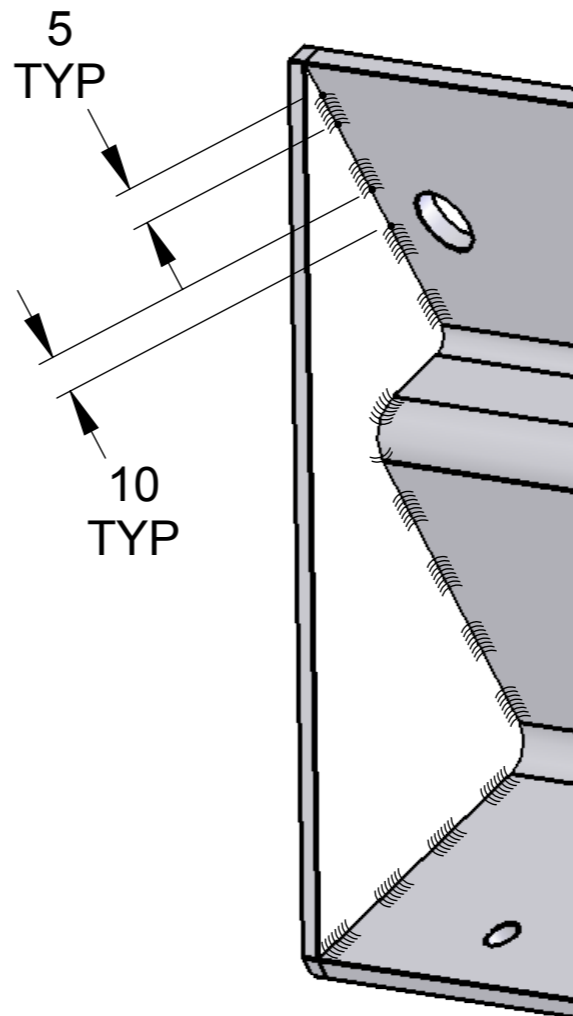
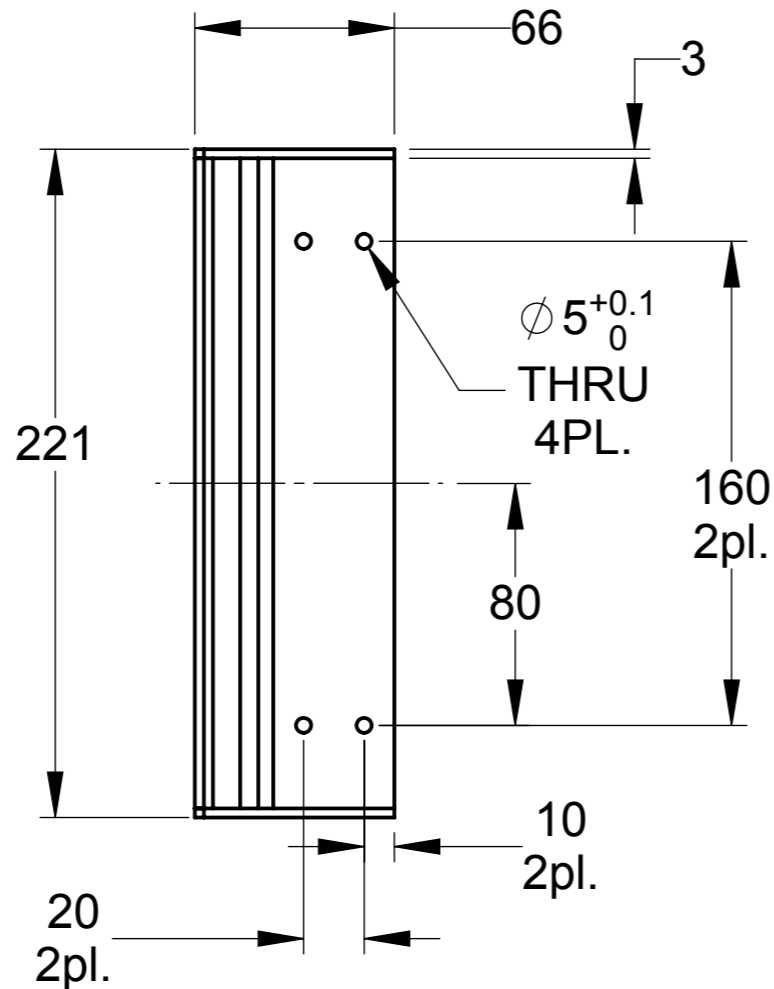
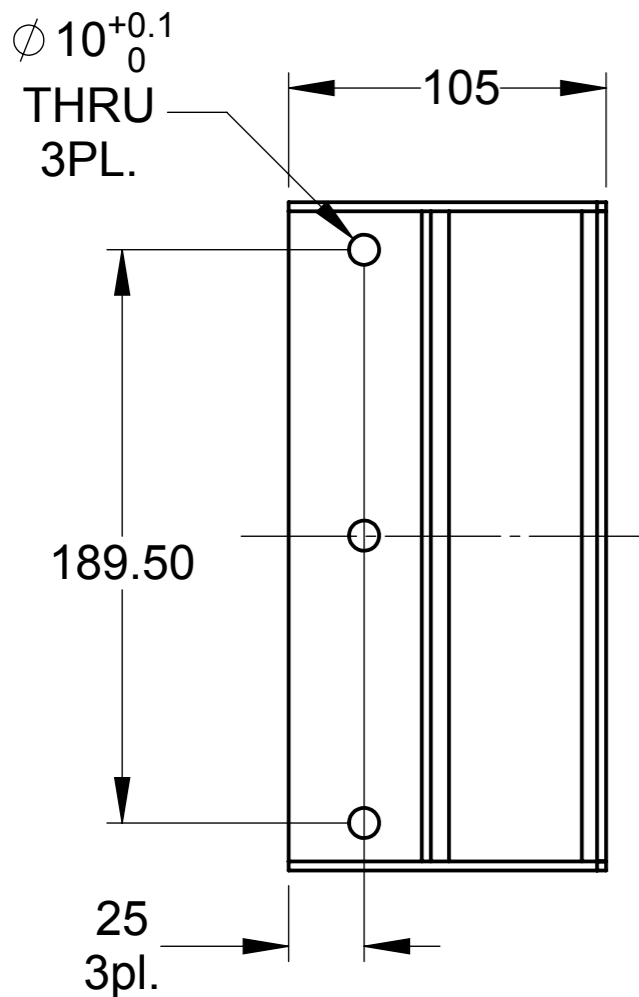

DETAIL A
SCALE 1 : 1

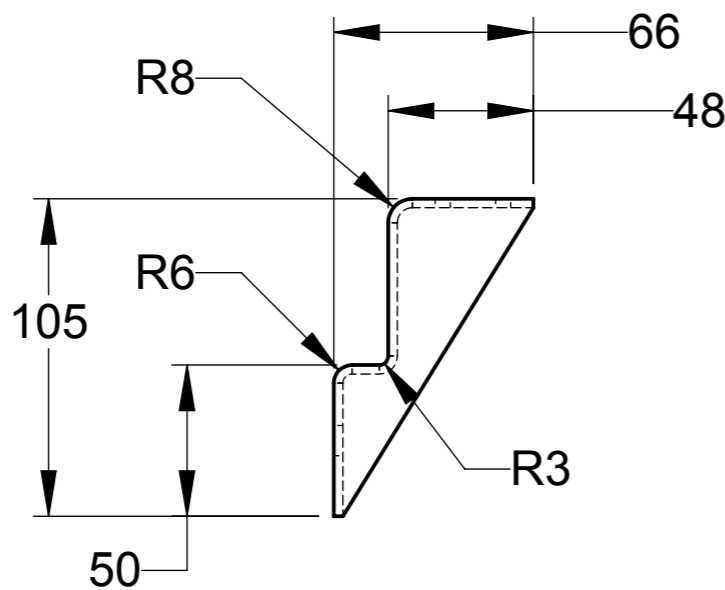

NOTES:

1. MATERIAL: AL.AL. 5052-H32 .
2. REMOVE SHARP EDGES.
3. SECTION WELDING 3V ACCORDING TO DRAWING IN BOTH SIDES.
4. ALODINE PER MIL-DTL-5541 Type 2 (RoHS) Class 3 - CLEAR
5. PACK THE ITEM AND MARK WITH PART NUMBER .

UNLESS OTHERWISE SPECIFIED		CONTRACT TO			
DIMENSIONS ARE IN mm PER ANSI Y14.5M-1982		DWG	Yael	Yael	16.6.16
TOLERANCE		CHKD			
LINEAR	ANGULAR	DSGN			
± 0.2	± °	PROJ	ROSTMY	M.R	16.6.16
		MFG			
		QA			



WIRELESS EDGE LTD.

TITLE

RADIO ADAPTER

MT-464042/ND/B

NEXT ASSY



SURFACE TEXTURE IN MICRO IN.

SIZE	DWG NO	
A3	MP44082000C	
SCALE-	SHEET 1 OF 1	
1:2.5		