



# RPST

## RemotePro™ Remote Power System

- Wireless Base Stations and Client Devices
- Surveillance Cameras
- Remote Sensors
- Remote Lighting
- Off Grid Electronics



***Congratulations!*** on your purchase of the RemotePro™ off-grid remote power system. Please take a moment to review this Qwik Install Guide before assembly or battery installation.



### **DANGER! Avoid Powerlines! You Can Be Killed!**

When following the instructions in this guide take extreme care to avoid contact with overhead power lines, lights and power circuits. Contact with power lines, lights or power circuits may be fatal. We recommend to install no closer than 20 feet to any power lines.

**Safety:** For your own protection, follow these safety rules.

- **Perform as many functions as possible on the ground**
- **Do not attempt to install on a rainy, windy or snowy day or if there is ice or snow accumulation at the install site or if the site is wet.**
- **Make sure there are no people, pets, etc. below when you are working on a roof or ladder.**



**Recommended Tools:** Phillips Screwdriver, 13mm and 10mm Wrench, 5/16" nut driver, Flat Blade Screwdriver



**Please help preserve the environment and return used batteries to an authorized depot**

# Qwik Install

**STEP 1:** Add Grounding Wire Between Door and Enclosure: Remove plastic covers on copper studs on inside of door and inside of enclosure. Add jumper wire between 2 copper studs and use copper washers and nuts to secure.



**STEP 2:** Remove the bottom cover and replace it with the PowerVent™ included with the package. Add wire feedthrus and any necessary connectors into the bottom PowerVent™ plate.

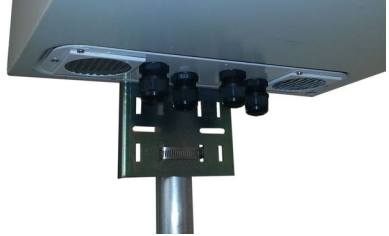

**STEP 3:** Install hole plug in drain hole in bottom right corner of the enclosure.

**STEP 4:** Mount the DIN rail to the door using screws provided. Mount any extra equipment to the orange backplate and secure the backplate in the enclosure. Note: The DIN rail can also be mounted to the orange backplate or sides of enclosure if desired.

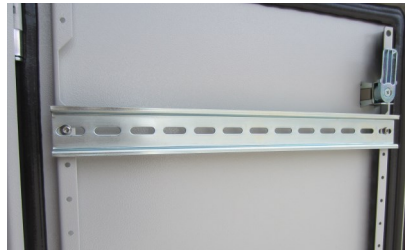

**STEP 5:** If pole mounting the enclosure, assemble the pole mount kit to the back of the enclosure and mount the enclosure to a pole using the 6 hose clamps provided. The enclosure can also be wall mounted using the 4 holes in the back of the enclosure.

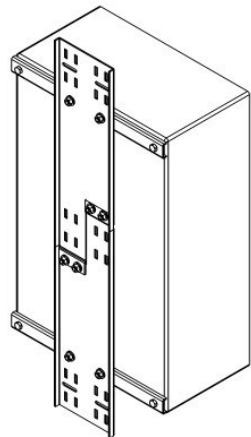
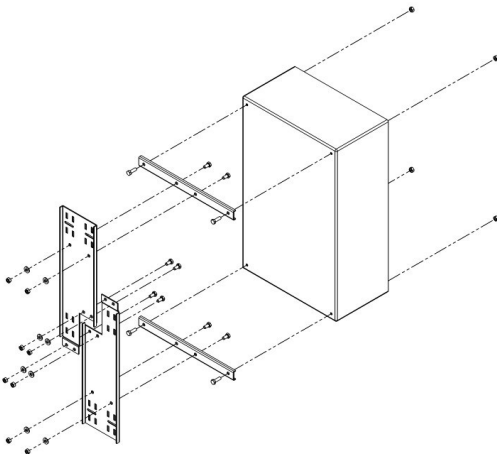

**STEP 6:** Insert the battery platform in the bottom of the enclosure. The battery platform has cutouts so wires can be routed under the battery as needed.



**STEP 7:** Attach the green DIN Rail adapters to the charge controller using the screws provided. Clip the controller to the DIN rail.

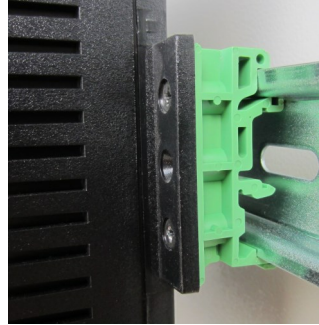

**STEP 8:** Assemble the solar panel mount and set the correct tilt angle based on your Latitude. There is a useful tool to calculate optimum angle at <http://tyconsystems.com> If you will be using a fixed angle all year we recommend using the optimum angle for winter sun. Mount the solar panel mount to the pole using hose clamps provided. Be sure to mount high enough so the door of the enclosure clears the solar panel mount when opened. You can also mount the panel to a wall using lag bolts.

**NOTE:** If the Solar Controller is model **TP-SCPOE12xx** you must wire batteries and solar for 12V configuration. If Solar controller is model **TP-SCPOE-24xx** you must wire solar panels and batteries for 24V configuration. Basically Batteries / Solar / Controller must be same voltage. The **TP-SC24-20** controller is auto ranging and will detect 12V or 24V.

**STEP 9:** Attach the solar panel to the solar panel mount so that the wire junction box is towards the top or inside. Remove the cover from the solar panel junction box by unscrewing or releasing the 6 snaps. Connect the wires to the + and - screws inside the junction box. Replace the cover making sure it is fully snapped.



**NOTE:** When wiring 2 panels in a 24V configuration you will have two unused wires on the cable assembly. Wrap the ends with electrical tape to avoid any shorting of the panels.

Wire the Solar Panels as shown below, depending on your installation:

12V Two Panel Configuration

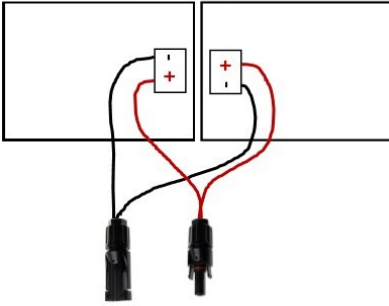

24V Two Panel Configuration

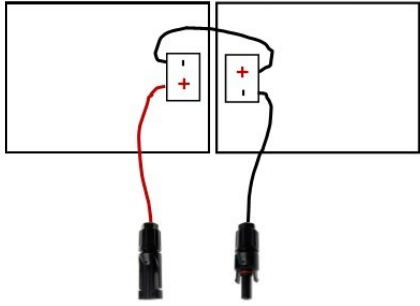

12V Four Panel Configuration

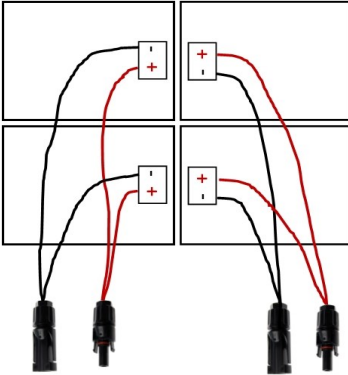

24V Four Panel Configuration

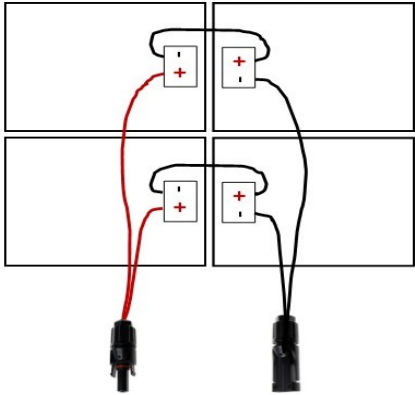

**STEP 10:** Install the batteries in the enclosure. If using multiple batteries, connect in parallel for 12V output or connect in series for 24V output.



If batteries are installed on their side make sure to apply an insulator (included) to the top of the battery terminal to prevent the battery terminals from shorting to the metal enclosure in case the battery shifts inside the enclosure during an earthquake.



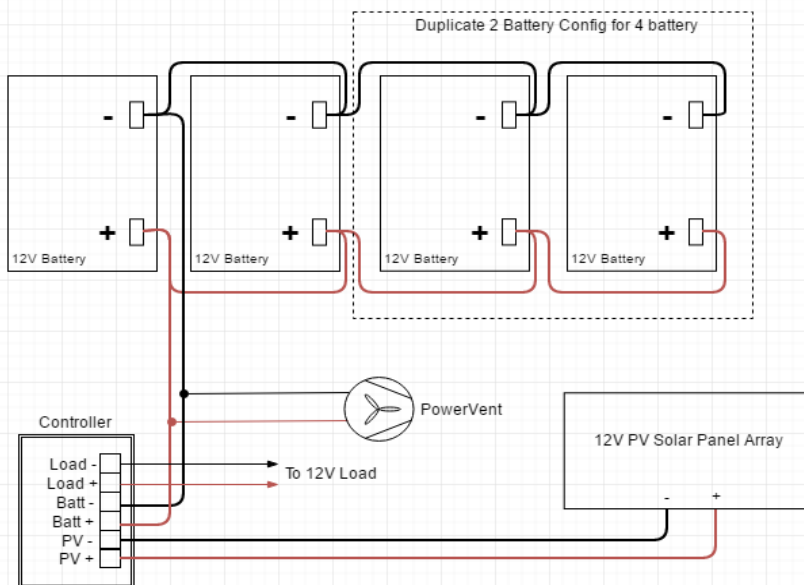

**RPST 12V Wiring Diagram**

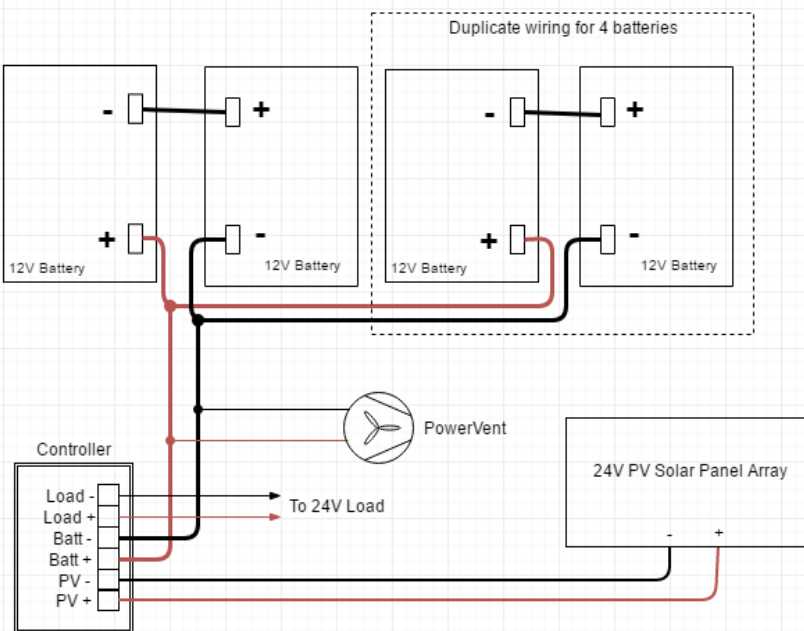

**RPST 24V Wiring Diagram**

**STEP 11:** Disconnect the green connector from the front of the controller. Connect the solar and battery wires to the green connector.

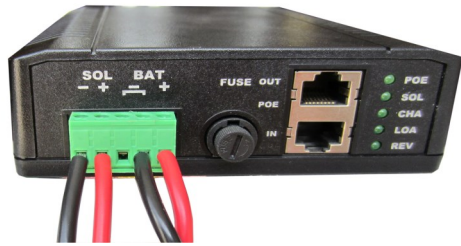

Connect the Battery cables to the Battery. Be sure to observe polarity. Black wire connects to battery negative terminal and BAT(-) terminal on the controller. Connect the green connector to the controller. When a fully charged battery is connected, the Green LOA LED should light on controller.

**NOTE:** The green connector on the controller may become unplugged due to vibration and the weight of the cables. Be sure to add a zip tie or other method to hold the cables and relieve the cable weight from the connector.

**NOTE:** On kits using the TP-SCPOE controllers, we have included a Gigabit passive PoE injector and adapter cable to be able to connect to the Aux port on the controller and provide passive PoE equal to the battery voltage. 24V Output is regulated.



**NOTE:** An alternate high capacity (20A) controller is shipped with the RPST12 and RPST24 systems. The controller has wire terminal solar, battery and unregulated load outputs.



**NOTE:** If there is no room for multiple cables on the controller input use wire nuts to combine two cables to one and connect the one cable to the controller.

**NOTE:** Be sure to connect the battery to the controller first and disconnect it last. Connecting solar panels to the controller without the battery connected could damage the controller.

**STEP 12:** Route the solar panel cables out thru the feedthrus and install to the solar panel. Be sure to connect in the proper polarity, red wire to + and black wire to -. Make sure connections are waterproofed.

**STEP 13:** Tighten all wire feedthrus. If they don't tighten on a small diameter wire, you can wrap some electrical tape around the wire in the seal area to increase its diameter and make a better seal.

**STEP 14:** Make sure lid gasket is clean and free from any particles, then carefully close the cover, making sure that wires are clear of the seam and hinge area. Use the special key to close the two cover locks.

# TP-SCPOE Controller Wire Terminal Output Wiring

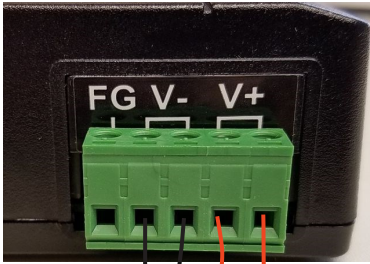

**FG** = Frame Ground. Connect to Earth Ground

**V-** (There are two V- connections)

**V+** (There are two V+ connections)



## TECH CORNER

### *Additional Information you may find useful*

1. **CONTROLLER:** The 12V controller turns off power to the load at 11V and reconnects when the battery reaches 12.5V. The 24V controller turns off power at 22V and reconnects at 24.5V. This protects battery from overdischarge and increases battery life and performance.

#### 2. TP-SCPOE Controller LEDS:

**POE** = ON POE input detects current from POE source. If POE led is flashing it means the power source is too weak for the POE input. Find a power source with more capacity.

**SOL** = ON Solar input detects current from solar panel.

**CHA** = ON Batteries are being charged from solar input. If CHA is flashing it means batteries are fully charged.

**LOA** = ON Battery voltage is sufficient and load outputs (POE OUT and auxiliary wire terminal output) are turned on.

**REV** = ON Battery wires reversed.

#### 3. Fuse:

There is a fuse in the controller (10A) and a fuse in the battery cable (20A). The fuse is in-line with battery power. If fuse is blown there was some sort of short in the battery connection and the controller will appear dead. Replace with 10A or 20A fuse.

4. **CAPACITY:** The RemotePro™ RPST is rated at either 20W, 35W or 65W continuous power output with 6 hours of peak sun per day.

5. **VENTING:** The enclosure is vented thru the PowerVent™. The fan is thermostatically controlled and will turn on when the temperature inside

the enclosure exceeds 45° C.

**6. BATTERY MAINTENANCE:** The batteries used in the RemotePro™ systems don't require any maintenance. They should last up to 5 years in normal use.

**NOTE: Never store batteries for any length of time in a discharged state or it will kill the battery.**

**1. SOLAR PANEL TILT:** There is a solar panel tilt calculator at the TyconSystems website <http://tyconsystems.com>. We recommend using a fixed tilt and setting to optimize for winter sun. The panel should face South if you are in the Northern Hemisphere or face North if you are in the Southern Hemisphere. Some typical winter tilt angles are as follows:

<i>Place</i>	<i>Optimum Winter Tilt</i>
Houston / Cairo	56 deg
Albuquerque / Tokyo	60.5 deg
Denver / Madrid	65 deg
Minneapolis / Milano	69.5 deg
Winnipeg / Prague	74 deg

**2. BATTERY OVERDISCHARGE:** We highly recommend hooking all equipment loads to the controller voltage output. This output will disconnect the load if the battery voltage drops below 11V (12V battery) or 22V (24V battery) and this will protect the battery from over-discharge. If batteries get completely discharged (<10V) because the equipment was connected directly to the battery, you will reduce the battery life and you will most likely need to recondition them with a good quality 10A automotive battery charger. Avoid charging for longer than 24hrs to avoid battery damage. Once they are back to a normal operating range, the integrated charge controller will maintain the charge.

### **3. TROUBLESHOOTING:**

- A. ***I only get the SOL light on my charger controller?***—The battery voltage and solar panel voltage must match the controller. If controller is TP-SCPOE-12xx it needs 12V solar and battery voltage. If the model is TP-SCPOE-24xx it needs 24V battery and solar voltage.
- B. ***There is no LOA light and no voltage output?***—If battery voltage is too low the charge controller will turn off the load outputs. On a 12V battery system the load will turn off if battery is <11V. On a 24V battery system the load will turn off at <22V.
- C. ***Why is my solar panel voltage so high?***- Open circuit voltage on a 12V panel is around 23V, and about 40V on a 24V panel.



# SPECIFICATIONS

Subject to change without notice

	RPST12xx	RPST12	RPST24xx	RPST24
<b>Battery Capacity</b>	100Ah or 200Ah		50Ah or 100Ah	
<b>Reserve Power @ Rated Load</b>	>24 hours		>24 hours	
<b>Wire Terminal Output Voltage (DC)</b>	12V 1.5A	12V 20A	24V 1.5A	24V 20A
<b>POE Output Voltage (DC)</b>	24V1.2A or 48V .62A	N/A	24V1.2A or 48V .62A	N/A
<b>Maximum POE Input Voltage (DC)</b>	57V	N/A	57V	N/A
<b>Battery Voltage (DC)</b>	12V		24V	
<b>Battery Type</b>	Valve Regulated Sealed Lead Acid / GEL			
<b>Battery Life</b>	5 Years			
<b>Controller Type</b>	Dual Input Solar/ POE, PWM, 12V/24V 10A	20A PWM	Dual Input Solar/ POE, PWM, 12V/24V 10A	20A PWM
<b>Overcharge Protection</b>	14.4V		28.6V	
<b>Over-discharge protection</b>	11V		22V	
<b>Over-discharge recovery voltage</b>	12.5V		24.5V	
<b>Controller Self Consumption</b>	<0.5W			
<b>Enclosure Type</b>	Powder Coat Steel			
<b>Operating Temperature</b>	-30°C to +60°C			

Once you connect to the charge controller the panel voltage will be reduced to a little higher than the battery voltage.

- D. *My system turns off at night and comes back on in the morning?***- This is a sure sign that the solar panels and/or battery capacity can't support the load. You should measure your actual load and recalculate to make sure you have adequate capacity.
- E. *Can I charge my batteries from AC power?*** The TP-SCPOE controller gives the capability to charge the batteries through the POE IN Port. The port accepts 24VDC or 36VDC @ 2.6A max. Tycon offers 90W power supplies and PoE inserters for this purpose.

## Replacement Parts

**Solar Controller:** TP-SC24-20 (20A Output) or TP-SCPOE-xxxx (With PoE output)

**Batteries:** TPBAT12-52

**Solar Mount:** TPSPM-80X4-UNI (2-4panels) or TPSPM30-80-SP (single panel)

**Solar Panel:** TPS-12-80W

## Wind Turbine

**TPW-400DT-12/24** 400W 12V/24V  
Wind Turbine

- Includes Integrated Controller with Dump Load
- Good low wind performance
- Self braking in high wind
- 110MPH survivability
- Sealed and maintenance free

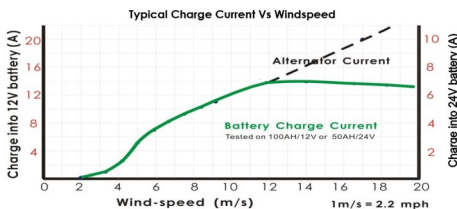

# RemotePro™ Typical Application—24V

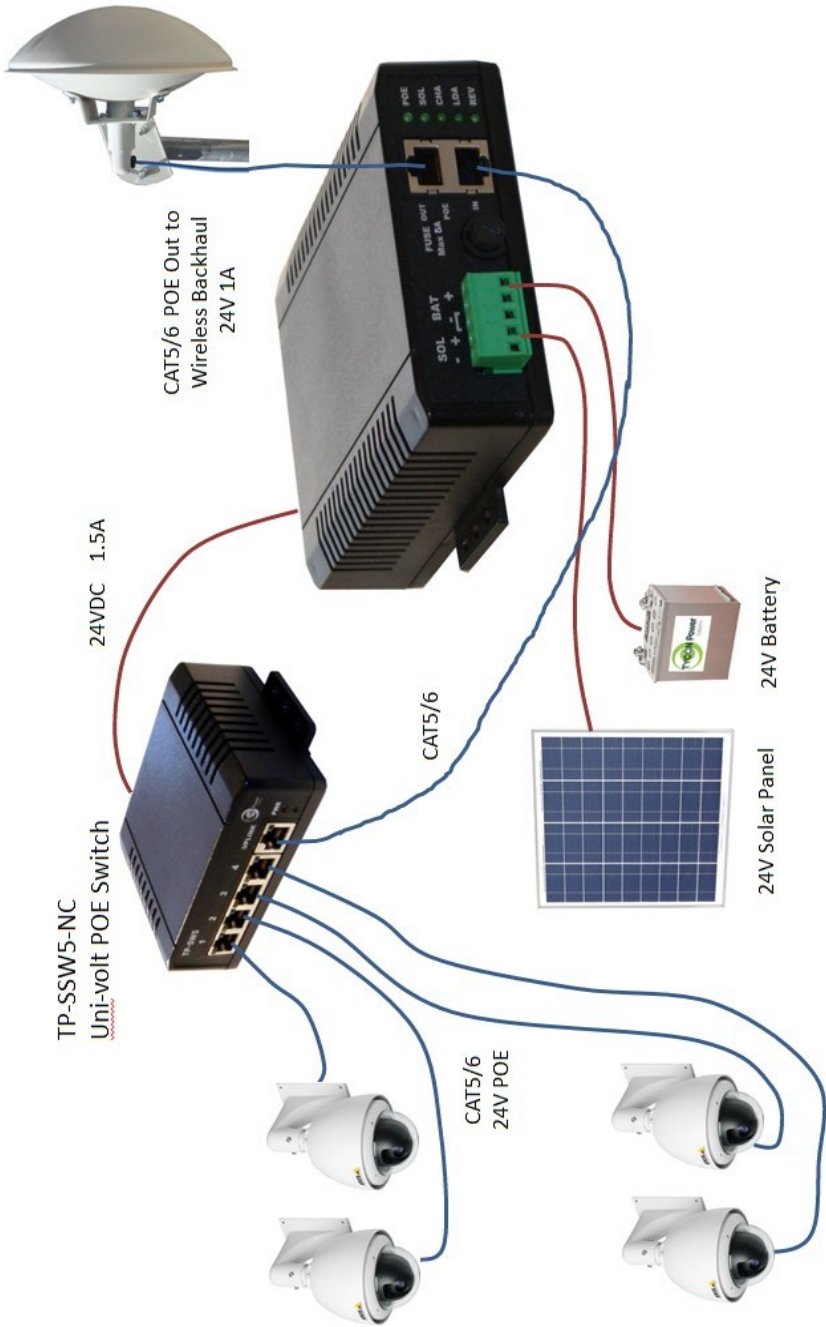



## Limited Warranty

The RemotePro™ products are supplied with a limited 24 month warranty which covers material and workmanship defects. This warranty does not cover the following:

- Parts requiring replacement due to improper installation, misuse, poor site conditions, faulty power, etc.
- Lightning or weather damage.
- Physical damage to the external & internal parts.
- Products that have been opened, altered, or defaced.
- Water damage for units that were not mounted according to user manual.
- Usage other than in accordance with instructions and the normal intended use.

Tycon Power Systems  
14641 S 800 W  
Bluffdale, UT 84065  
support@tyconsystems.com  
PH: 801-432-0003